



EN

RAMPF Production Systems

Innovative production systems with integrated dispensing technology

RAMPF

#DiscoverTheFuture

Chemical and Engineering Solutions



Advanced Polymers



Composite Solutions



Machine Systems



Production Systems

RAMPF Production Systems is a company of the international RAMPF Group.
Find out more on page 28.

RAMPF Production Systems

Innovative production systems with integrated dispensing technology

RAMPF Production Systems is a leading international developer and supplier of mixing and dispensing systems for sealing, casting, and bonding.

With our core competence mixing and dispensing technology as well as our extensive automation and process expertise, we develop holistic solutions for our customers' production facilities.

Whether in a technical or commercial field, as a trainee, graduate, or experienced professional – everyone at RAMPF can put their knowledge, experience, and talents to good use.

One of our major strengths is our comprehensive portfolio of solutions for processing single-, dual-, and multi-component reactive plastic systems. We have already developed more than 3,300 system solutions worldwide – from simple manual systems right through to fully automated production plants.

The close cooperation with customers and our wide range of services are the key success factors. This is why around a third of our 220 employees are in direct contact with customers.

As a medium-sized family business, we rely on the outstanding skills of our team and first-class training. Our company headquarter combines an idyllic setting with innovative prowess – Zimmern ob Rottweil is located on the edge of the Black Forest, a region that is home to numerous high-tech mechanical engineering companies.



Find out more at youtube.com/rampf-group

Your industry | Your application

Quality. Progress. Performance.



AUTOMOBILE AND VEHICLE CONSTRUCTION

- ABS control units
- Air conditioning
- Door assembly carriers
- Door handles
- Display
- Electronics / sensors
- Lighting
- Mount-on components / spoilers / design
- Speakers

CONSTRUCTION

- Air conditioning units
- Fire doors
- Luminaire housing

ELECTRICAL / ELECTRONIC INDUSTRY

- Control cabinets
- Inverters
- Luminaire housing
- Sensors

E-MOBILITY

- Battery housing
- Battery sensors
- Charging connectors
- Heat management
- iBooster
- On-board chargers

FILTERS

- Air filters for cars
- HEPA filters
- HVAC filters
- Oil filters

HOUSEHOLD APPLIANCES

- Dishwashers
- Oven doors and hobs
- Sinks
- Washing machines and dryers

MEDICAL TECHNOLOGY

- Blood filters
- Orthopedic mattresses
- Oxygenators
- Respirators

SPORT AND LEISURE

- E-bike batteries
- Sports shoes
- Video screens



Products and services

Developing innovative solutions is our daily business.

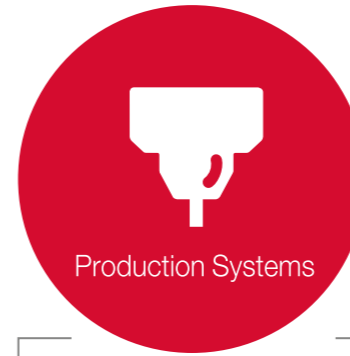

TECHNOLOGIES



Innovative, high-performance, sustainable:

Mixing and dispensing systems for processing all conventional reactive polyurethane-, silicone-, and epoxy-based plastics – from water-thin to highly viscous.

TECHNICAL PRODUCTION SYSTEMS

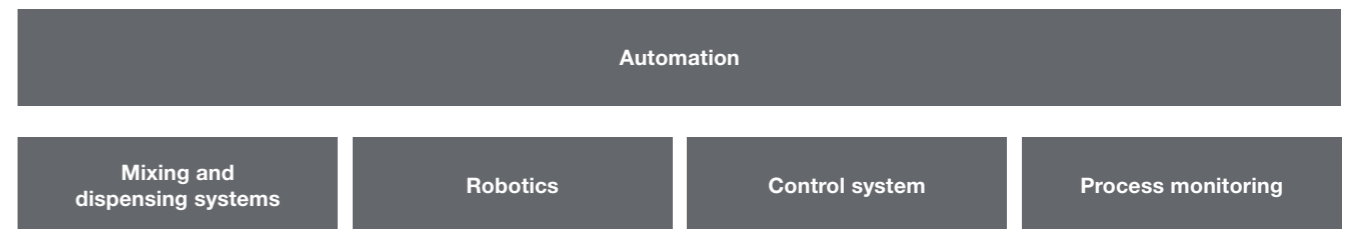

Precise, solution-oriented, customized:

Project-specific automation concepts with integrated parts transport and heat treatment; assembly and joining technologies; logistics and quality-assurance solutions.

SERVICES



Customer-oriented, skilled, committed:

Comprehensive consulting services – from the initial inquiry right through the system's service life.

+ YOUR BENEFITS

- > Best fit solution for every technology
- > Dynamic mixing technology provides for optimal results when mixing different viscosities – also for difficult mixing ratios
- > Static mixing of very small to very large discharge quantities



Casting

TECHNOLOGIES

Innovative. High-performance.
Sustainable.



Sealing



Bonding

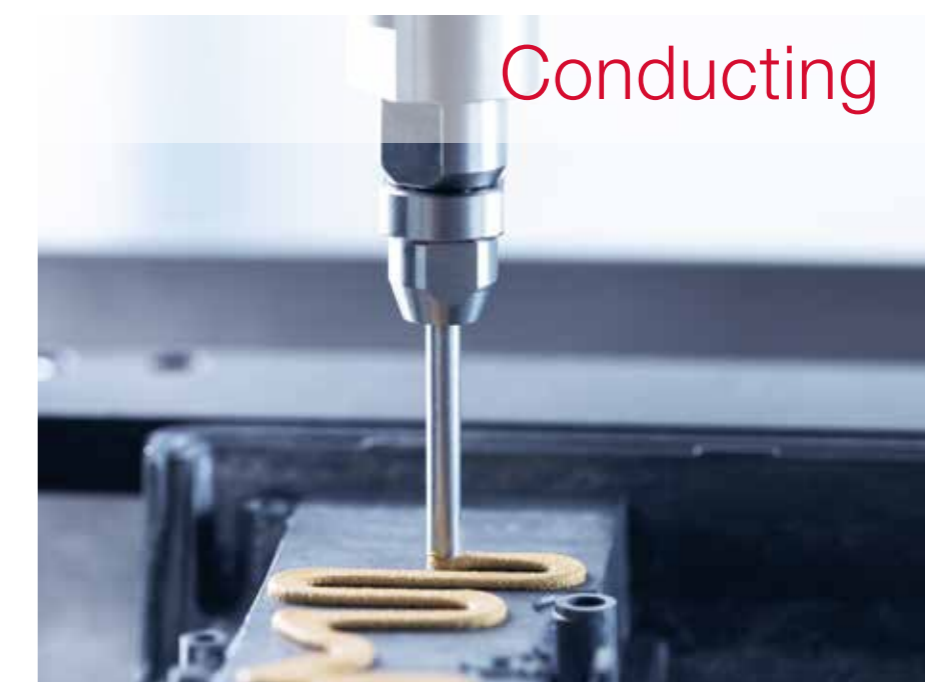

Conducting



TECHNOLOGIES

Sealing.

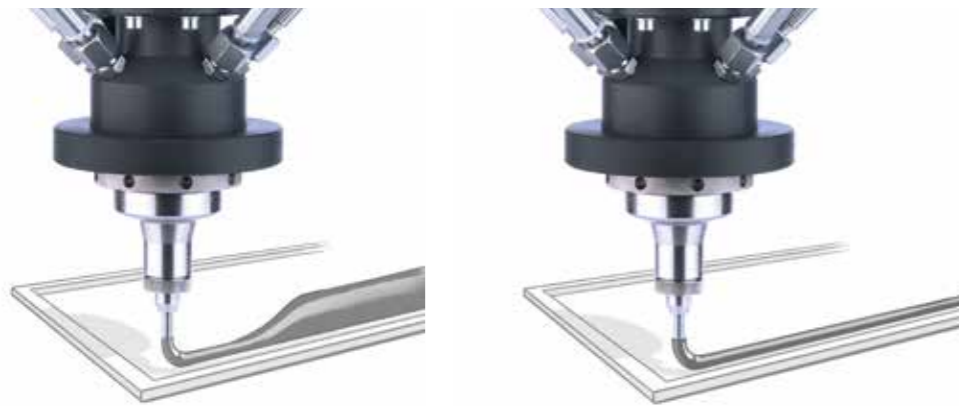

FOAMING (FIPFG)

We process multi-component reactive polyurethane and silicone foams into sealants. Multi-axis robots apply these to level and curved surfaces fully automatically. After curing, a seamless gasket (formed in place foam gasket = FIPFG) is bonded to the component and provides static protection against dust and moisture. The foams can also be dispensed into a carrier mold and processed further as a custom-fit, cured gasket (molded foam).

SEALING (FIPG)

With dispensing technology and robot-assisted automation solutions, sealing beads made of polyurethane and silicone are applied to a wide variety of components. The elastomers can be applied to flat and curved surfaces. After curing, a non-detachable, elastic gasket (formed in place gasket = FIPG) is bonded to the component and provides static protection against dust and moisture. Flexible production systems with surface activation for improving adhesion, heat treatment, and quality monitoring ensure optimum production results.

+ ADDED VALUE

- > Maximum productivity thanks to customer-specific system design
- > Consistent material quality thanks to regulated air load
- > Low-maintenance dynamic mixing technology

+ ADDED VALUE

- > Consistent material quality through dynamic or static mixing processes
- > Precise overlapping points thanks to displacement-free shut-off technology
- > Integrated systems for improving adhesion, rapid curing, and leakage testing



Find out more at
youtube.com/rampf-group

Casting.

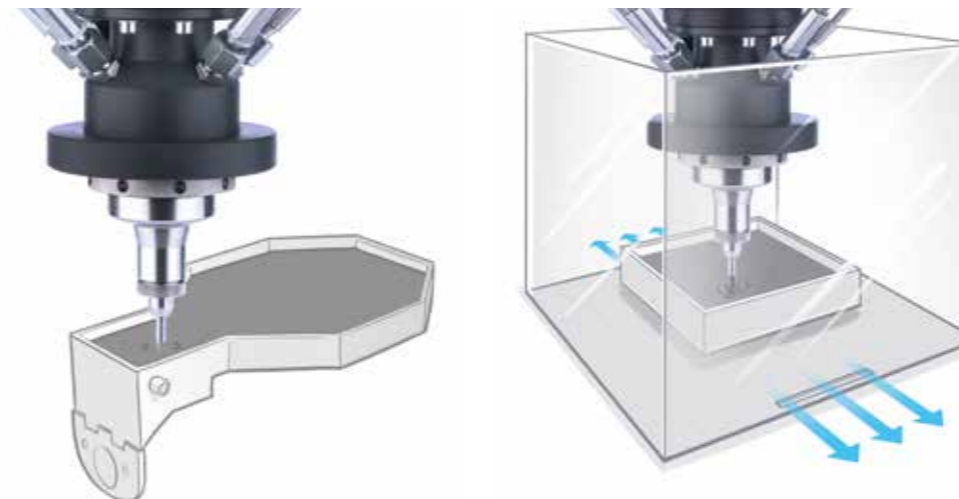

CASTING UNDER ATMOSPHERE

Sensitive electronic assemblies are permanently protected from contact, moisture, and damage through a single-stage or multi-stage casting process, whereby usually two-component casting materials based on polyurethane, silicone, or epoxy resin are used to reliably embed the components. A highly effective material preparation unit for air degassing ensures a bubble-free casting process.

CASTING IN A VACUUM

Electronic components with windings, narrow gaps, or shapes that are difficult to vent are cast without air bubbles in a vacuum. The components meet the highest insulation requirements and continue to deliver maximum performance under extreme conditions. The vacuum technology is also used for producing optically transparent connections (e.g. for manufacturing displays).

+ ADDED VALUE

- > Reliable insulation and protection of components through casting materials with different viscosities and densities
- > Process reliability through low-maintenance static or dynamic mixing technology with perfectly coordinated dispensing pumps and material preparation
- > Short cycle times and exceptional quality results thanks to automation concepts developed by RAMPF



Find out more at
youtube.com/rampf-group

Bonding.



BONDING

We process all kinds of multi-component adhesives into precise reactive products for joining components. The components can be pre-treated to improve adhesion. The high-precision joining process can be manual or fully automated. Integrated curing-on-demand systems accelerate the curing process. When joining components in a vacuum, products such as displays are affixed without air bubbles (optical bonding).

+ ADDED VALUE

- > Optimum reactivity thanks to dynamic or static mixing technology, including for viscous adhesives
- > Permanently stable joints thanks to integrated surface activation
- > Short cycle times thanks to intelligent joining tools



Find out more at
youtube.com/rampf-group

Conducting.



CONDUCTING

Reactive polymer-based pastes that are thermally and electrically conductive protect sensitive electronic components by dissipating heat and electrostatic charge. Thanks to the powerful mixing and cleaning technology of our wear-resistant dispensing systems, the highly filled, multi-component gap fillers are optimally processed and then dispensed with pinpoint accuracy using our robot systems. With the help of integrated process monitoring and quality control, we ensure the best production results.

+ ADDED VALUE

- > Permanent conductivity and protection of electronic components through the precise dispensing of highly abrasive conductive pastes
- > Static mixing, including for the smallest dispensing quantities
- > Low-wear piston dispensing systems ensure maximum precision, even at high dispensing speeds



+ YOUR BENEFITS

- > Dynamic mixing technology for optimum reactivity of materials with different viscosities
- > Reliable production thanks to standardized process technology integrated into a holistic solution
- > You benefit from the experience we have gained from over 3,300 projects

Dispensing technology

High-precision. Low-maintenance.

Our core competence

We are the market leader for high-performance, low-maintenance process technology for sealing, casting, and bonding a wide variety of polymer systems.

We know that every production process places unique requirements on a dispensing system's components. By precisely coordinating material transport and preparation systems, mixing technology, and dispensing solutions, we ensure perfect dispensing results.



+ YOUR BENEFITS

- > One partner for the entire automation process
- > Standardized graphical user interface for easy use and quick maintenance
- > Installation and maintenance with certified service staff – worldwide



TECHNICAL PRODUCTION SYSTEMS

Precise. Solution-oriented.
Customized.

Control technology
Innovative. User-friendly. Intuitive.

HMI user interface for optimum connectivity and user guidance

We use controllers from Siemens and Beckhoff to optimize the efficiency, speed, and reliability of our dispensing systems and robots.

Thanks to the newly developed RAMPF HMI, our customers also have a universal user interface at their disposal.

This ensures platform-independent connectivity with all common mobile devices and allows for a universally adapted visualization for ease of use.

The small number of user levels makes for a simple, intuitive, and easy-to-navigate operating concept.



Dispensing systems

Optimized production processes.



DC-CNC 250

The compact desktop dispensing cell is specially designed for processing highly viscous and abrasive one- and two-component materials. It features a static mixing unit with a cartridge supply system, piston dispensing pumps, and nozzle monitoring. Thanks to freely programmable point-based or length-based dispensing, thermally conductive pastes, casting compounds, and adhesives can be dispensed flexibly and with the highest accuracy.

+ ADDED VALUE

- > Low-maintenance static mixing system with nozzle monitoring
- > User-friendly control system
- > Precise dispensing of highly abrasive, electrically and thermally conductive materials (gap fillers)

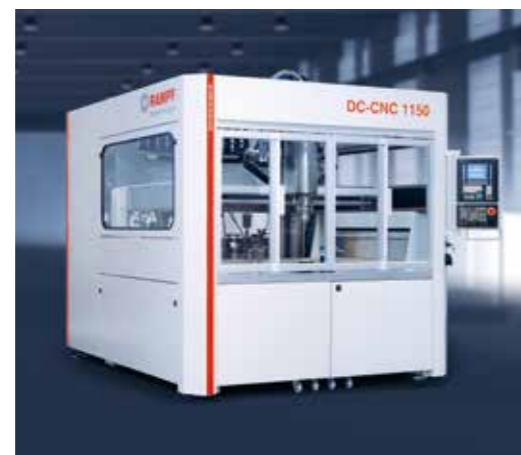

DC-CNC 800 / DC-CNC 1150

By combining mixing and dispensing technology with maintenance-free CNC linear axes, the compact dispensing cells meet even the most complex requirements. They have an integrated material preparation system and offer the choice of either piston or gear pumps. They can be flexibly integrated as part of an automation solution. Cutting-edge control technology ensures flawless interplay between dispensing process and motion sequences.

+ ADDED VALUE

- > Processing of up to four components in one or two mixing systems
- > Can be flexibly integrated into production lines or as a stand-alone solution
- > Manual or automated part supply

Dynamics. Interaction. Data management.



DR-CNC

The dynamic three-axis system supports the high-precision movement and positioning of the mixing head, thus ensuring reliable sealing, casting, and bonding with maximum flexibility. The dispensing robot can be implemented as a stand-alone solution with a work table, sliding table, or conveyor system, and can also be integrated into a fully automated production line. The modular control architecture allows for complete and easy integration into production systems.

+ ADDED VALUE

- > Custom robot-controlled manufacturing concepts for all dispensing applications
- > Maximum flexibility thanks to highly adaptable X-Y-Z travel axes
- > Optimized output through the use of two mixing systems



DC-VAC

The vacuum dispensing system is designed for processing one- and two-component casting compounds, which are dispensed via a static or dynamic mixing system without air bubbles. An upstream material degassing system ensures the highest quality standards are met. The vacuum chamber can be configured for manual loading or integrated into a fully automated concept. Additional control systems simplify process monitoring.

+ ADDED VALUE

- > Reliable casting without air pockets, e.g. for sensitive electronic components
- > Can be used as a stand-alone solution or in an interlinked process
- > Consistent material quality through integrated recirculation via the mixing system

Best results.



C-DS

The compact C-DS dispensing system is a vital component of all RAMPF automation solutions (C-DS+) and designed to be integrated into a wide variety of modular production concepts. It comprises a material preparation, dispensing, and mixing system, a PLC controller, and built-in process monitoring. The structure of the dispensing system ensures a high degree of flexibility for seamless integration into production lines.

+ ADDED VALUE

- > Compact, adaptable, and freely expandable to suit all dispensing tasks
- > Thanks to its modular design, it can be flexibly integrated into existing production lines
- > Highly versatile – from manual workstations and automated partial solutions to fully automated robot systems



MC

The modular structure of the RAMPF MC multipurpose cell ensures dispensing systems and custom automation equipment for testing, joining, and assembly can be integrated with ease. The system is available in various standard dimensions and can be equipped with small robots, linear axes, conveyor belts, rotary and sliding tables. The multipurpose cell ensures a space-saving automation concept, be it as a stand-alone solution or integrated into a production line. Systems from Siemens and Beckhoff are available for the controllers.

+ ADDED VALUE

- > Flexible and compact automation solutions
- > Dispensing, processing, and assembly in the smallest of spaces
- > Intuitive operation via RAMPF HMI

Automation

Comprehensive process expertise

for maximum speed and consistent quality of your manufacturing process

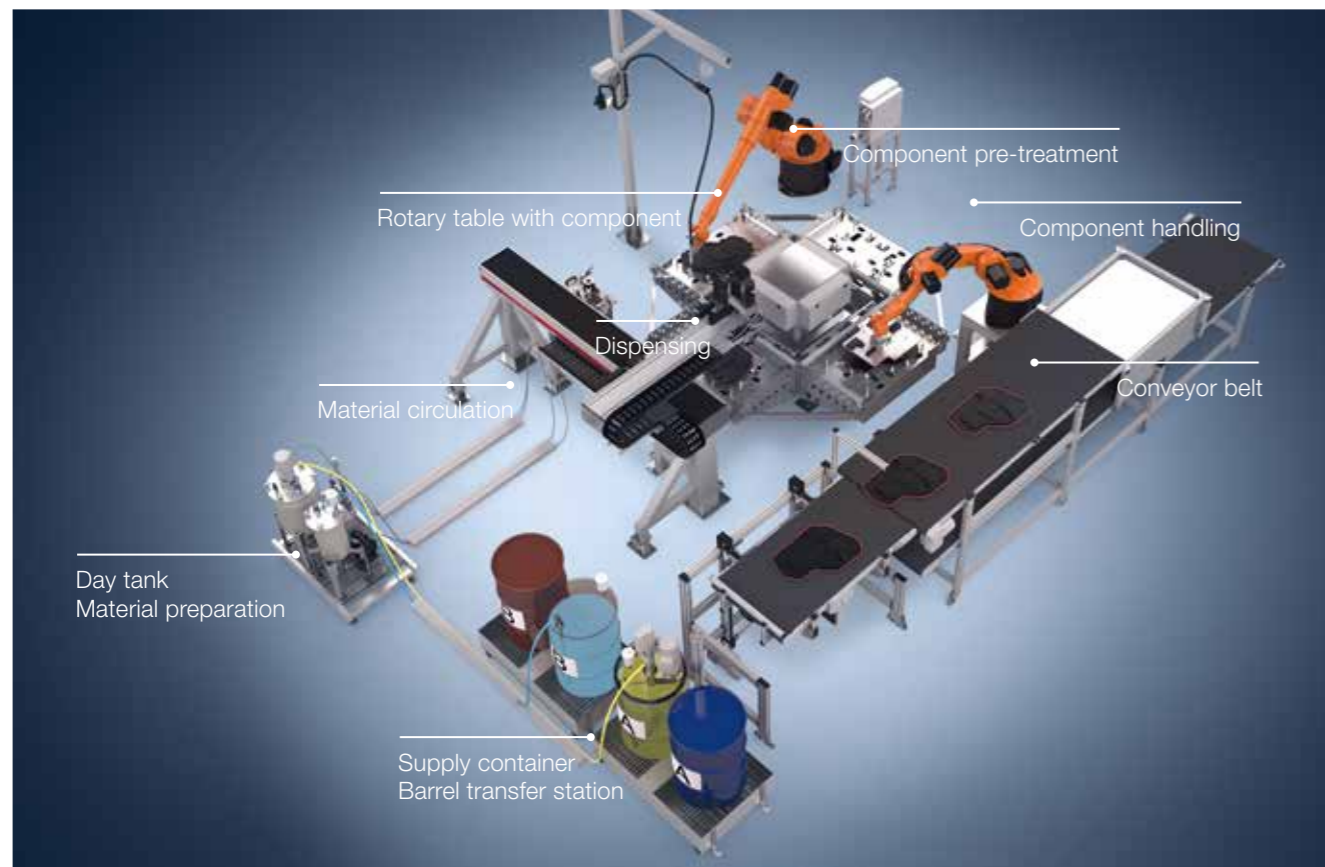

We are the market leader in automation solutions for mixing and dispensing technology. We design and manufacture customer-specific production systems based on our standardized components. In other words, we only use tried-and-tested process technology for each sub-task.

To fully automate your processes, we use robots from KUKA, ABB, and FANUC, which are programmed to suit your exact needs. Integrated systems for material pre-treatment, curing, and visual quality inspection ensure optimum production results.

We deliver every system with our universal RAMPF HMI on request and make all process information available to higher-level systems. This means the system can be controlled with just one intuitive and user-friendly interface.

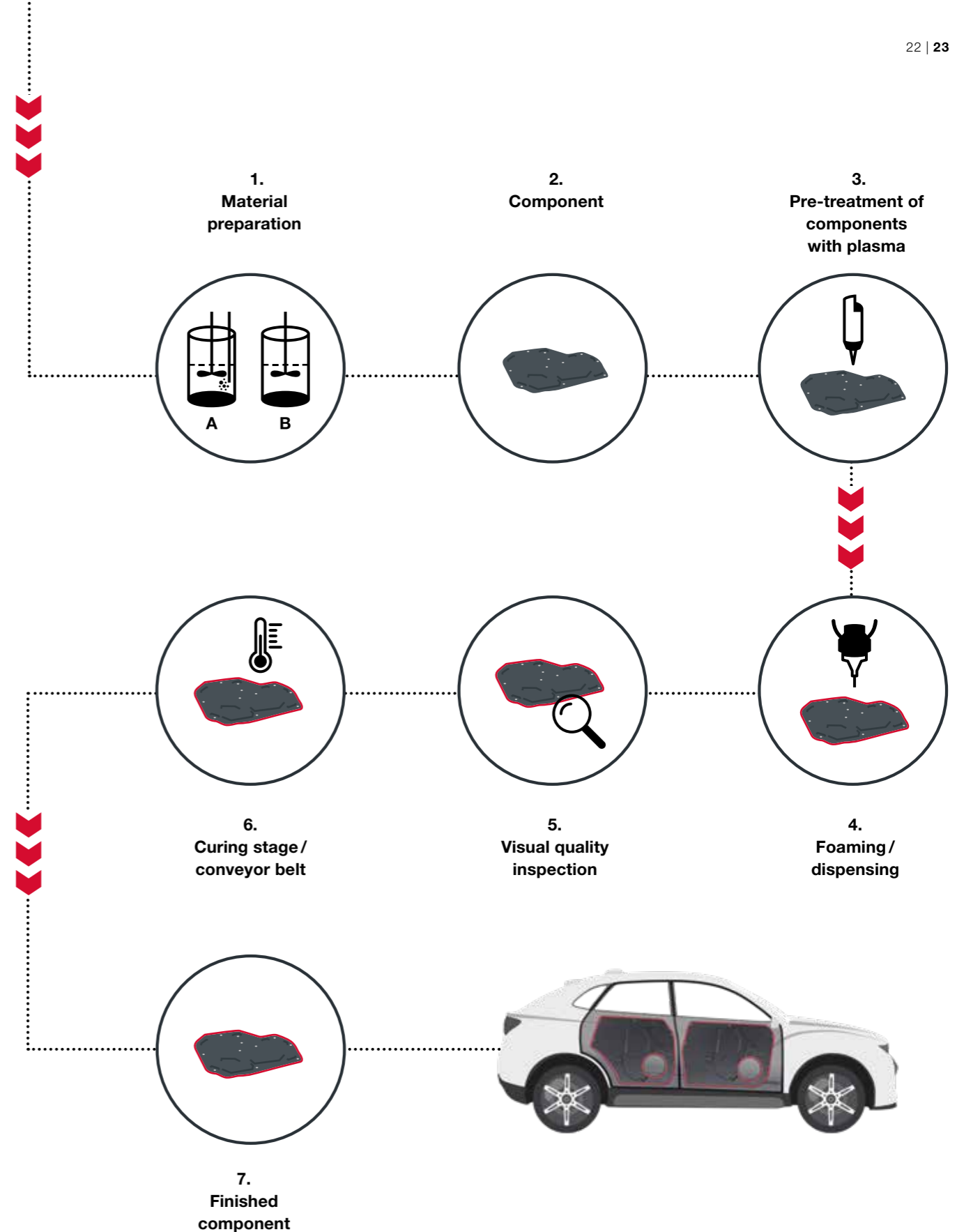

Example:
Dispensing a sealing bead on a door assembly carrier



Automation

Comprehensive process expertise

for maximum protection and optimum product functionality

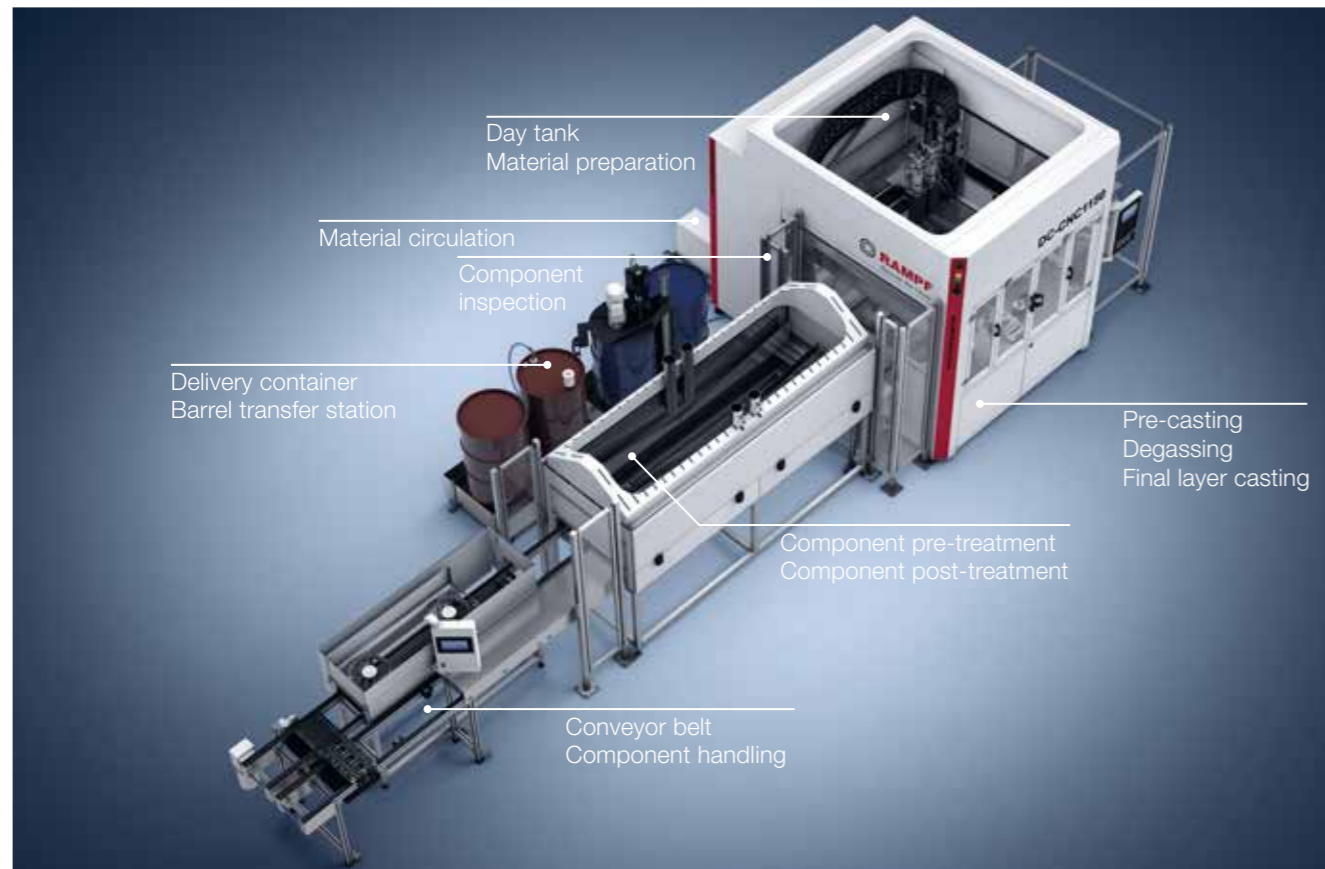

Sensitive electronic assemblies must be permanently protected from external influences.

Our experienced team develops and designs automated systems for the bubble-free casting process of your products under atmosphere. For components with complex geometries with windings or potential cavities for air pockets, the casting is carried out in a vacuum.

Using our modular cell concept together with tried-and-tested dispensing and process technology, we develop a customized, automated production line to suit your requirements. This includes extensive component pre- and post-treatment, degassing, and multi-stage casting. The system is operated via a universal HMI user interface, regardless of the Siemens or Beckhoff controller used. Reliable monitoring technology ensures a high-quality casting process for your products.

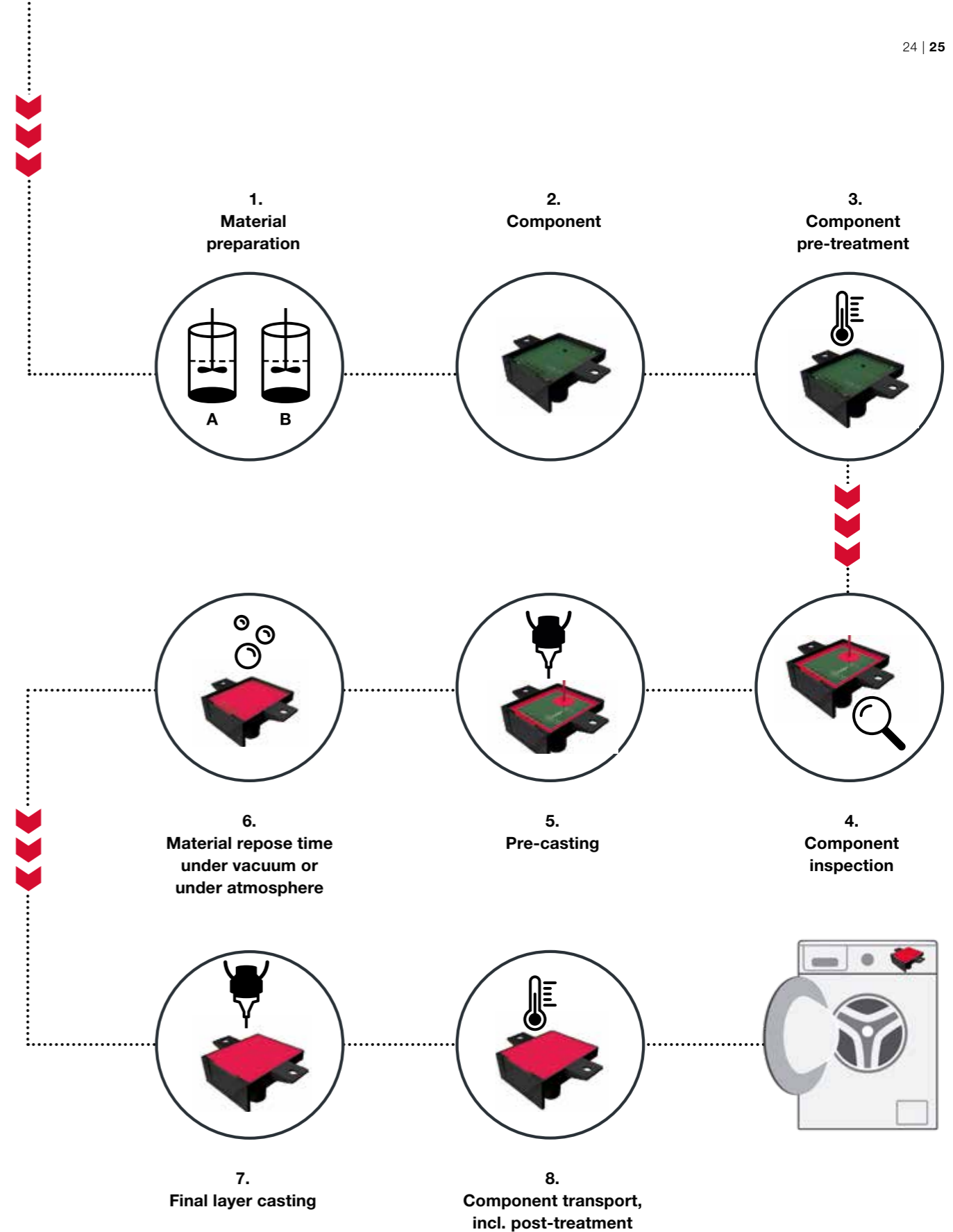

Example:
Casting sensitive electronic assemblies and sensors





+ YOUR BENEFITS

- > Fast expert support for the entire life cycle of your machine

- > Material and processing technology from a single source – the complete service from RAMPF

- > RAMPF – your holistic development partner and service provider

Services and solutions

Expertise and commitment

For your success – from the idea to the finished product

We find the best solution for your requirements. Why? Because of the comprehensive application experience we have gained from the successful implementation of over 3,300 projects. And because our engineering, application technology, and automation experts work together for your success.

APPLICATION ENGINEERING

Initial feasibility studies are created in application engineering and prototypes and samples developed. Long-term tests provide detailed information on maintenance costs and performance data, as well as initial stimulus for further improvements to products and production processes.

SMALL SERIES PRODUCTION SERVICE

We produce parts for you on our machinery in accordance with your process requirements to bridge delivery times or to support series launches. We offer production capacity for sealing, foaming, casting, conducting, and bonding. In our ISO 7-class clean room, casting and bonding processes are conducted to the highest cleanliness requirements – including in a vacuum.

RAMPF TEC-ACADEMY

Maintenance, programming, and process training can be booked as either individual or group courses. The course content is tailored to your requirements.

ONLINE CUSTOMER PORTAL

Our service begins as soon as your system is delivered. You can request comprehensive services such as training, maintenance contracts, retrofitting, and repairs at any time through the RAMPF Project Cockpit – our convenient online customer portal.



We are inventors. Team players. And a strong partner.

RAMPF stands for pioneering chemical solutions and visionary engineering. Worldwide.

From a one-man operation to an international group with twelve sites spread across three continents – with our products and solutions centered around reactive resins, machine systems, and lightweight construction with composites, we rank among the market leaders in a whole host of industries.

Discover the future – this is both our corporate slogan and the foundation of our long-standing success story. In close cooperation with our customers and partners, we develop tomorrow's products and solutions today – for the decisive competitive advantage.

Sustainability has been a priority right from the outset. This is no mere buzzword but an integral part of our day-to-day activities. As pioneers of chemical recycling, we have been contributing to an effective circular economy for decades. The raw materials that we recycle are used both by our customers and within our Group.

We are also a sustainable employer. RAMPF grows with its employees – we invest in our staff and are keen for them to work with us in the long term. We achieve this by openly showing appreciation and offering extensive training and development opportunities.

A forward-looking, sustainable, and value-creating family-run business – as a partner to industry and as an employer, we attach the greatest of importance to trust and reliability. These qualities are an absolute must when it comes to establishing long-term, successful partnerships.

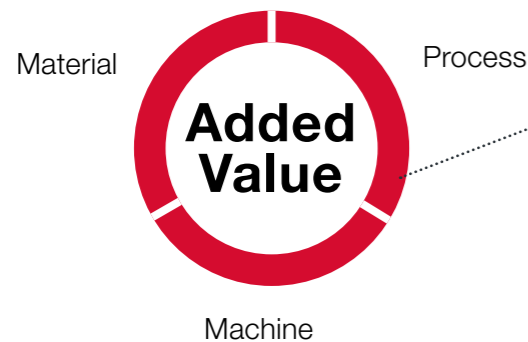

RAMPF – Chemical and Engineering Solutions.
Utilize our wide-ranging innovative potential for Added.Value.

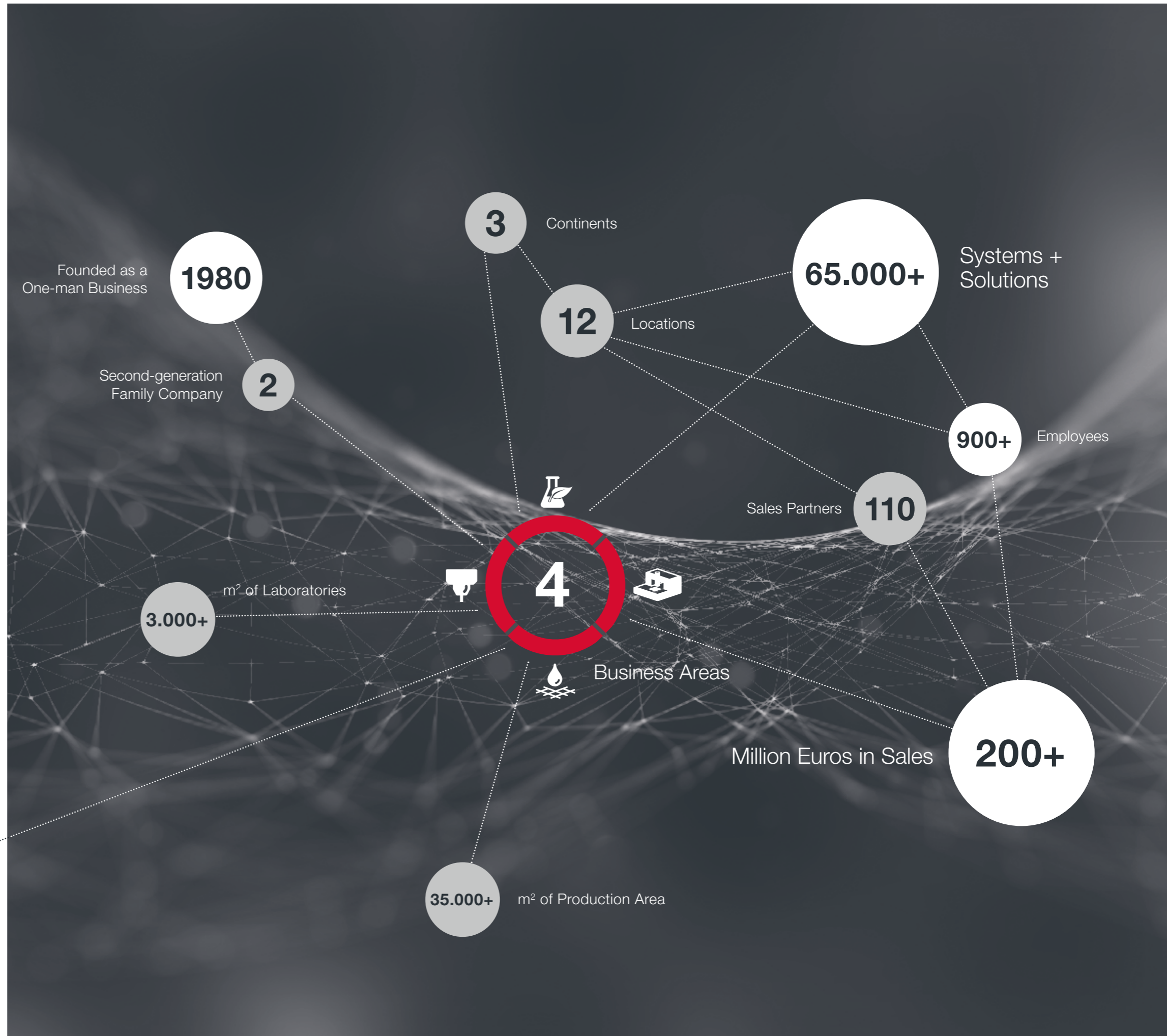



RAMPF –

discover the future

Developing the Solutions
of Tomorrow – Today.

+49.741.2902-0

production.systems@rampf-group.com

Mass production?
Not at RAMPF.

**We engineer
made-to-order solutions.**

