

Product Information Dispensing Robot DR-CNC

Highest Flexibility – dynamic Sealing, Casting and Bonding



Dispensing robot DR-CNC with shuttle tables and automated part unloading



Dispensing robot DR-CNC with pallet conveyor system

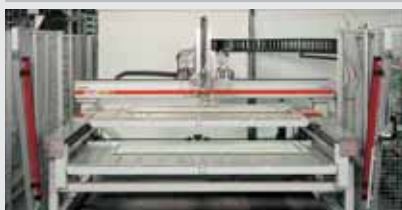

Dispensing robot DR-CNC with over/under shuttle tables



Dispensing robot DR-CNC with multi-level curing belt

Your advantages

- » **RAMPF High-speed axis**
 - Steel/aluminum axes with maintenance-free linear-motion ball bearings for extended lifetime
 - rack-and-pinion drive
 - Maintenance-free servo-drives
- » **Accurate metering**
 - High precision servo-driven gear metering pumps for up to 4 components
 - Short hoses between metering pumps and mixing head for highest precision
- » **10" colour display with PC**
 - Easy process overview through extensive process visualisation
 - Unique material database to allow easy and flexible programming
- » **Highest productivity**
 - Increased productivity through optional dual mixing system
 - High travel speed during dispensing
- » **Integrated process monitoring**
 - Permanent monitoring of pressures, pump speeds and material levels



RAMPF[®]
discover the future

Dispensing Robot DR-CNC

Product Details

The DR-CNC is the ideal solution for all complex applications. Variable X-Y-Z strokes enables three-dimensional dispensing of sealants, glues or encapsulants. The DR-CNC is equipped with the highest standards in NC technology to control the dispensing process with the linear motion of the CNC-axis. The result: best teamwork between metering process and motion axis. The modular architecture of the NC allows for simple and entire integration in existing production control systems.

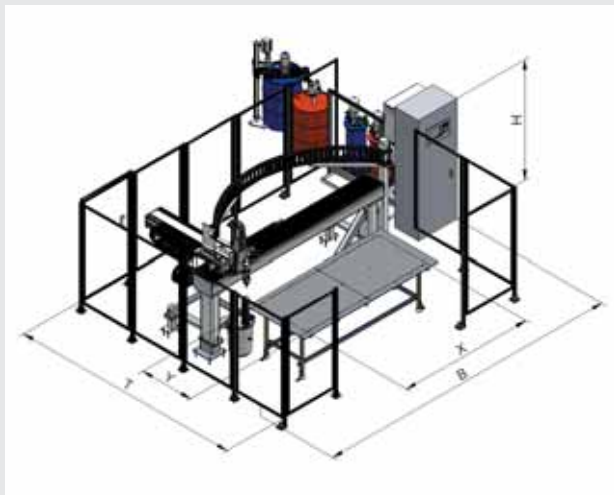

Work areas (details see chart)

X-Axis		Y-Axis		Z-Axis	
X-stroke	Size B	Y-stroke	Size T	Z-stroke	Size H
500	1.630	500	1.920	250	2.200
750	1.880	750	2.420	400	2.400
1.000	2.280	1.000	2.930		
1.500	2.780	1.250	3.430		
2.500	3.760				
3.000	4.600				
3.650	5.300				
5.000	7.000				

Technical Data (subject to change)

Dispensing capacity, Mixing ratio, Number of compents, etc.	Depending on installed mixing system
Maximum travel speed	x,y = 60 m/min.; z = 24 m/min.
Repeatability	< 0,15 mm (ISO 9283)
NC controls	Siemens Sinumerik 810D/840D
Dispensing programs	99
Power supply	400 V / 16-32A / 50Hz (60 Hz)
Power consumption	5,5 – 12 kw
Compressed air supply	> 5 bar at max. 800 l/min.
Compressed air consumption	5-20 l/min.

Options (more on request)

- » High-pressure rinse recycling system or high-pressure water rinsing
- » Nucleation controller for density control of foam materials
- » Material recirculation system with temperature control
- » Automatic thin-film degassing system for bubble-free casting
- » Various types of automation equipment available
- » Customized production and process data monitoring and production data collection
- » 12" colour display, customized interfaces
- » Gantry axis for bigger work area
- » Up to 5 material components